



# TECH TIPS

## SERVICE TIPS FOR THE AUTOMOTIVE TECHNICIAN

### ALTERNATIVE CODE RETRIEVAL PROCEDURE FOR FORD EEC IV SYSTEMS

The Ford EEC IV system is used on Ford vehicles starting with the 1984 model year. Unfortunately, the "Check Engine" light was not used until 1988. So, unlike the earlier models that did not have the light, these models give a visual indication of when the ECM detects a problem. In addition to alerting the vehicle operator, the "Check Engine" light can be used to retrieve EEC IV fault codes. This can be done without the use of a scan tool and is a convenient way to perform Ford's "Key-on, engine off" (KOEO), and "Key-on, engine running" (KOER) tests. For those of you that are working on a 1984-87 vehicle without the light, we will give you an alternative to perform the same tests. Before we do that, let's review Ford's self-diagnostic strategy.

**NOTE:** These tests should be performed on an engine that is at operating temperature, otherwise, false fault codes may be set. Also, make sure that all switches, including the air conditioner and defroster, are in the off position.

**KOEO test:** This is a static test of major sensors and actuators used by the EEC IV system. During this test, the sensors and wiring are being tested for open circuits, short circuits, or, for being out of the prescribed range of operation. If a sensor performs out of the expected range, or, an actuator does not perform as

expected, an "On Demand" fault code is generated. This terminology is used to define that the ECM presently sees a problem in the system. An "On Demand" code can only be cleared by repairing or replacing the faulty part of the circuit. Once the fault is no longer present, the ECM will no longer set that particular "On Demand" code. On some systems, depending on the fault code, the ECM will not allow you to perform any other tests until these faults are corrected.

**Continuous Memory Codes:** Although this is not a test in itself, it is the second part of the KOEO test. Whenever the engine is running, the ECM continuously monitors its inputs and outputs. If a sensor or actuator does not perform as expected, a fault code is stored in memory. Codes that are stored in Continuous Memory indicate that at one time the ECM had detected a problem or problems in the system, even though that problem may not currently exist as indicated by a lack of an "On Demand" code. These codes may also cause the "Check Engine" light to illuminate during engine operation.

#### KOER test:

This is a dynamic test performed with the engine running. During this test, sensor response will be monitored when the ECM alters the air/fuel mixture and actuates various outputs such as solenoids and actuators.

During this test it will request the technician to snap the throttle, apply the brakes, turn the steering wheel, and toggle the overdrive switch. Codes generated during this test indicate that a sensor or actuator did not respond as expected by the ECM. Remember, some systems will not allow this test if there are any On Demand codes that have not been fixed.

Now that we have explained the test strategy, we will explain how to run these tests without the use of a scan tool.

The KOEO test is the place to initiate this procedure. First, locate the diagnostic connectors which are usually placed in the engine compartment (see diagram #1). The single wire connector is designated as the STI or Self Test Input terminal. If you connect this terminal to a good ground, and turn the ignition to the "ON" position, you will notice several events that will take place. The "Check Engine" light (if equipped) will turn off, the fuel pump will run briefly, the cooling fan(s) will run briefly (if controlled by the ECM), and all of the other ECM-controlled actuators will be switched on and off

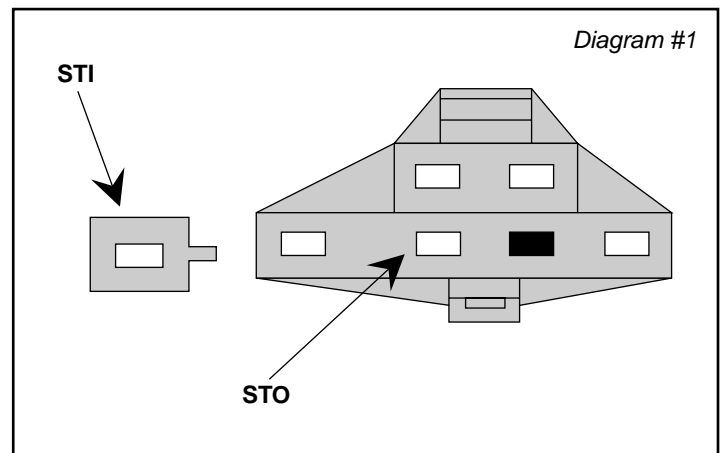

# TECH TIPS

SERVICE TIPS FOR THE AUTOMOTIVE TECHNICIAN

one time. At this point, fault codes that exist will be displayed by the “Check Engine” light.

The first set of codes to appear are the “On Demand” codes. These may be two or three digit codes, depending on the model year. A flash sequence of 5 flashes, followed by a pause, followed by 1 flash, followed by a pause, followed by 9 flashes, indicates a code 519. A pause, approximately four-seconds in length occurs between codes. If more than one “On Demand” code exists, the ECM will flash each code once, and will repeat the sequence a second time. A pause of approximately 5 to 7 seconds followed by a single flash of the “Check Engine” light will now occur. This sequence separates the “On Demand” codes from the “Continuous Memory” codes. These codes appear the same way as the “On Demand” codes.

“Continuous Memory” codes, as opposed to “On Demand” codes, can be cleared without performing any repairs. In order to do this, you must remove the ground from the STI terminal while you’re in the KOEO self test and the “Check Engine” light is flashing codes. If the problem is still present, the fault code will reset itself immediately. By the way, erasing codes by disconnecting the battery is not the advised way, since it will also erase the ECM’s adaptive strategy which may create idle control problems.

The KOER test is the next step in the diagnostic procedure. In order to initiate this test, with the ignition switch in the off position, ground the STI terminal. Now, start the engine. After a few seconds, the engine speed will increase momentarily and the “Check Engine” light will flash. The number of flashes will indicate the number of cylinders. Two flashes indicates a four cylinder, three

indicates a six cylinder, and four indicates an eight cylinder engine. After you receive this verification, the ECM is looking for you to apply and release the brake pedal, turn the steering wheel one half turn, and toggle the overdrive switch (if equipped). After these inputs by you, the ECM performs additional tasks in order to test the engine systems. The ECM changes the air/fuel mixture to test the oxygen sensor. Idle speed is changed to check the idle air bypass valve. The EGR system is activated while the ECM looks for a change in engine response. If the vehicle is equipped with an air pump, air is diverted upstream to test control valve operation. At this point the ECM will flash the “Check Engine” once to indicate to you that it wants you to snap the throttle. Snapping the throttle will help the ECM to check the operation of the Map sensor, Throttle Position sensor, Mass Air Flow sensor, and, if equipped, the Knock sensor.

After this sequence, any fault codes will be transmitted through the “Check Engine” light in the same manner as the KOEO test. Fault codes that appear indicate a problem that the ECM detected during that particular test. Fault codes as a result of this test do not need to be erased. If the problem is corrected, the next KOER test will not display that code again. If there are no fault codes detected for any of these tests, you will receive a pass code of 11 or 111, depending on the system used in that vehicle.

Using the above methods to initiate the self-tests makes sense for a few reasons. First, it is very quick. The KOEO test takes less than two

minutes. Second, there is no special test equipment that is required, other than a jumper wire to ground the STI terminal. Finally, it is a sure way to verify that any codes your scanner may indicate are real, and not as a result of a scanner malfunction. It is a cheap alternative in case you have not had your scanner updated to operate on the test vehicle.

In the cases where you are working on a vehicle without a “Check Engine” light, you can achieve the same results with an analog voltmeter, or a logic probe. For the voltmeter, just connect the positive lead to the battery positive terminal. Connect the negative lead to the STO (Self Test Output) terminal (see diagram #1). For the logic probe, connect the logic probe’s leads to the battery, and then touch the probe’s tip to the STO terminal. In either case, after you’re hooked up, just ground the STI terminal as discussed previously, and count either the meter’s needle sweeps or the logic

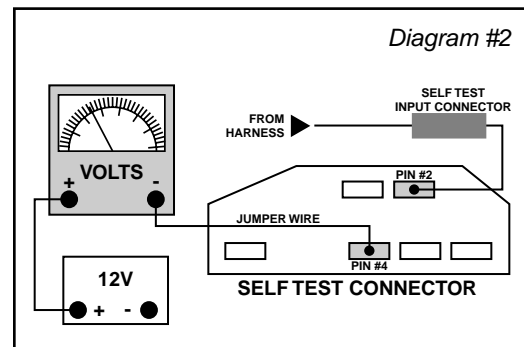

probe’s LED flashes (see diagram #2).

There are additional tests that can be performed with this system, regardless of the equipment you are using in order to retrieve codes. First is the Output State Test. This test will activate all of the ECM’s controlled outputs except the fuel pump relay, the cooling fan, and the fuel injectors. The outputs can be energized or de-energized by depressing the

throttle. This test is may be initiated after the KOEO test is run. After the Continuous Memory codes have been displayed (if any), just step on the throttle once to energize the outputs. For example, the EGR solenoid will be turned on when the throttle is depressed. If you depress the throttle a second time, the solenoid will be turned off. The “Check Engine” light will alternately illuminate and turn off, depending on the Output State. This works for all of the ECM’s controlled outputs.

Another test is the Cylinder Balance test. This particular test can only be performed on vehicles with Sequential Fuel Injection. The ECM performs this test by briefly disabling the fuel injectors one at a time while the engine is running. The ECM will also identify the malfunctioning cylinder by flashing the “Check Engine” light. The number of flashes indicates the cylinder number.

The Cylinder Balance test can be initiated after the KOER test. After any codes have been flashed, increase the engine speed by about 600 RPM for 2 seconds. This will signal the ECM to start the test. This can be confirmed by hearing the engine speed increase. After several seconds, the ECM will start to shut off the fuel injectors, one at a time. When this happens, engine RPM will decrease. If there are any weak cylinders, they will be identified by the flashes of the “Check Engine” light. This test can be repeated, if necessary, by increasing engine RPM as before. If there are no weak cylinders, you will receive a “Pass” code of 99. This will be indicated by nine flashes, a pause, followed by nine more flashes of the light.

*Pat Sugar*  
— *Top Gun technician*

## HITACHI MASS AIR FLOW SENSORS

Many technicians believe that the Hitachi brand mass air flow sensors which GM uses on its 3300 and 3800 engines never have a problem. The fact is that even though they are more reliable than most types, they do have some problems. While these sensors do not fail completely, they tend to slow down in their response under load. This is where many technicians get fooled when they use an oscilloscope to check the sensor’s output. When checking this sensor, the fact that the sensor generates a clean square wave is not sufficient. It is the frequency of that signal which the ECM uses to determine engine load. The same applies when using a frequency meter or a scan tool. At idle, all information appears to be normal. We must go beyond the basic checks at idle.

When these sensors do not perform properly, they usually exhibit a problem at higher RPMs in that they cannot generate the proper frequency fast enough so that the ECM can compensate for engine load. The ECM never generates a fault code because the sensor does generate a signal. It’s just not fast enough to respond properly to rapid changes in engine load. The symptom is usually some type of lean stumble upon acceleration and you may even get a code 44 (exhaust lean) at high speed cruise. After checking the basics, the first step is to disconnect the sensor’s connector. At this point the ECM will use a default value depending upon throttle position and engine load. This default value is the ECM’s approximation of air flow. In the case where the sensor is not performing up to par, the car may run better with it disconnected.

However, it is not as precise as the actual sensor’s input. Next, monitor the actual air flow on your scan tool. With the vehicle in park (block the drive wheels, and use the parking brake), snap the throttle while observing the grams/second on the scan tool. Reconnect the sensor’s plug. As before, snap the throttle while observing the scan tool. What you will usually see with a slow sensor when you snap the throttle, is that the air flow (grams/second) is about 30% lower than the default value.

This is the tip off that the sensor is the cause of the lean stumble. For example, with a 3300 engine, when the throttle is snapped, you usually see a default value of about 80 grams/ second. If the sensor you are testing is slow, you will probably see about 60 grams /second or less. If the sensor is functional, you should see close to 80 grams/ second. If the test verifies that the sensor is slow, then it must be replaced.

*Joe Dantuono*  
— *Top Gun technician*

## TOYOTA 1986-1989 CELICA- NO START, NO SELF DIAGNOSTICS

If you run into a Toyota Celica that is a no start which lacks ignition spark and injector pulse, and will not do self diagnostics, take a look at the “Check Engine” light to see if it is illuminated with the ignition switch in the “On” position. If it’s not, then the next step is to make sure that the 5-volt reference signal is present at the air flow meter and the throttle position sensor. The air flow meter is a potentiometer. It has a seven-wire connector, and it is located on top of the air

# TECH TIPS

SERVICE TIPS FOR THE AUTOMOTIVE TECHNICIAN

cleaner housing. One of the seven wires in the connector is a pink wire with a blue stripe. This is the 5-volt reference signal from the ECM to the air flow sensor as well as the throttle position sensor. You can start your diagnostics by checking for the presence of the 5 volts at the throttle position sensor. Ideally, this check should be made with the sensor connected. If the 5 volts are not present, unplug the throttle position sensor. If the 5 volts are now present, the reference voltage is being shorted to ground inside of the throttle position sensor circuit. If the 5 volts do not appear, the next step is to unplug the air flow meter. If, after unplugging the air flow meter, the 5 volts come back, then the voltage is being shorted in the air flow meter. In either situation, the part must be replaced.

Vince Walsh  
— Top Gun technician

## FORD PRESSURE FEEDBACK EGR SYSTEMS

In an attempt to control vehicle exhaust emissions, Ford advanced their EGR systems with the introduction of the EGR position sensor. This gave the ECM some idea of how much exhaust gas was being recycled. This system works pretty good when everything is new. However, as vehicle mileage increases, carbon buildup becomes a problem. This system has only one way to control and measure EGR flow, and this is based on the assumption that everything will work as expected. This leaves something to be desired.

Ford improved upon this by enabling the ECM to control EGR as well as monitoring EGR flow.

There are two styles of EGR control. The first is called Pressure Feedback EGR (PFE). This is a system where the ECM can determine EGR flow based on a pressure drop across the opening in the EGR passage by using a transducer. Based on this input, the ECM, using an EGR vacuum regulator, will control the vacuum signal to the EGR valve. By regulating the vacuum signal that controls the EGR, the PFE system enables the ECM to precisely compute and command proper EGR flow (see diagram #3).

The second style of EGR control is called the Differential Pressure Feedback EGR (DPFE). In this system, the ECM computes and controls EGR flow in a similar manner as the PFE system, except that this system calculates the difference in pressure between the EGR opening and the exhaust system (see diagram #4).

It is important to know that even though these two systems measure exhaust pressure, and are ECM controlled, there are physical and electrical differences that you should be aware of when performing diagnostics.

Physically, the PFE sensor has one pressure input nipple. The DPFE sensor has two pressure input nipples. Electrically, both the PFE and the DPFE sensors are three wire sensors. Each have a 5-volt reference from the ECM, a ground, and a sensor output. It is in the sensor output voltage where these two sensors differ.

The Key On Engine Off voltage output for the PFE sensor is 3.25 volts, where the output for the DPFE sensor is 0.45 volts. Refer to the charts to check pressure versus sensor output. Pressure can be checked by tapping into the pressure line while performing a road test and verify the correct voltage output. This system is pretty good at determining whether or not the system is functioning properly. If the ECM detects something is wrong, it will set a fault code. The most common problem is carbon clogging the ports. Even though the same problems plague the EGR system, these newer systems are better able to detect these problems before they become a major problem.

Julio Oyola  
— Domestic specialist

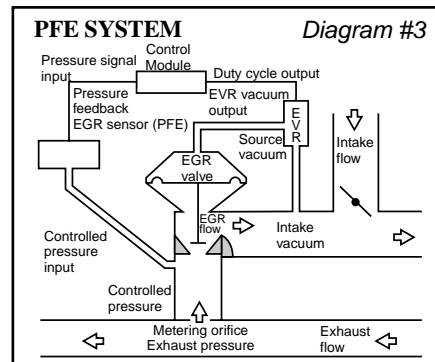

Pressure	Voltage
0 PSI	3.25 volts
.50 PSI	3.66 volts
.75 PSI	3.78 volts
1.00 PSI	4.08 volts
1.25 PSI	4.28 volts
1.50 PSI	4.50 volts
1.80 PSI	4.75 volts

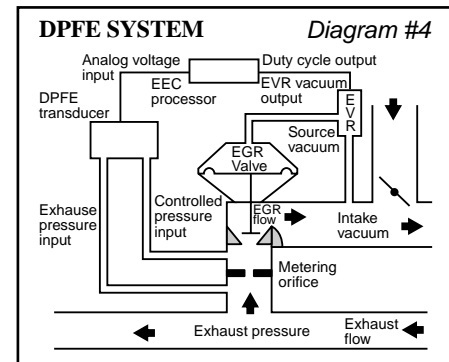

Pressure	Voltage
0 PSI	.45 volts
.50 PSI	.90 volts
1.00 PSI	1.40 volts
1.50 PSI	1.90 volts
2.00 PSI	2.40 volts
2.50 PSI	2.80 volts
3.00 PSI	3.30 volts
3.50 PSI	3.80 volts
4.00 PSI	4.25 volts
4.50 PSI	4.60 volts